

MOTO-TRAC Model 160 Curtain Tracks - Curtain tracks (Model 1600) shall be of 16 gauge aluminum, consisting of two side-by-side runways entirely enclosed except for slots in bottom, and shall be in one continuous piece except where splicing clamps are required. Curtain carriers (Model 1131) shall be spaced on 6" centers (4" centers optional) and shall be composed of a non-wheel-binding block supporting two polyethylene wheels rolling on two parallel treads. One end of the track shall contain a Dead-end pulley (Model 1634) with a 1-1/4" dia. steel ball-bearing wheel adjustable for cable tension. The other end shall be equipped with a 1/30 HP gearmotor with limit switches activated by the drapery carriers. Start-stop-reverse action shall be provided by a magnetic control system and push button type remote control switches.

Model 160 as manufactured by Automatic Devices Company of Allentown, PA.

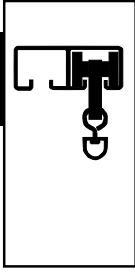

MOTO-TRAC® 160 SERIES CURTAIN TRACKS

160	MOTORIZED		MANUAL	
	160 Motorized Standard 6" Overlap	160 Motorized Unlimited Overlap	160 Hand Operated 6" Overlap	160 Hand Operated Unlimited Overlap
1131	●	●	●	●
1132	●	●	●	
1602		●		●
1602-R	●			
1624	●	●	●	●
1603			●	●
1604	●		●	●
1135			●	●
C040	●	●		
1150			●	●

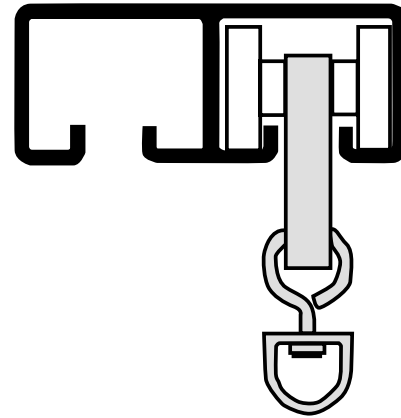

Full Size End View

SPECIFICATIONS:

MOTO-TRAC® Model 160 Curtain Tracks

Curtain tracks (Model 1600) shall be of 16 gauge aluminum, consisting of two side-by-side runways entirely enclosed except for slots in bottom, and shall be in one continuous piece except where splicing clamps are required. Curtain carriers (Model 1131) shall be spaced on 6" centers and shall be composed of a non-wheel-binding block supporting two polyethylene wheels rolling on two parallel treads. One end of the track shall contain a Dead-end pulley (Model 1634) with a 1 - 1/4" dia. steel ball-bearing wheel adjustable for cable tension. The other end shall be equipped with a 1/30 HP gear motor with limit switches activated by the drapery carriers. Start-stop-reverse action shall be provided by a magnetic control system and push button type remote control switches.

Model 160 as manufactured by Automatic Devices Company of Allentown, PA.

MOTO-TRAC® Model 160 Hand Operated Curtain Tracks

Curtain tracks (Model 1600) shall be of 16 gauge aluminum, consisting of two side-by-side runways entirely enclosed except for slots in bottom, and shall be in one continuous piece except where splicing clamps are required. Curtain carriers (Model 1131) shall be spaced on 6" centers and shall be composed of a non-wheel-binding block supporting two polyethylene wheels rolling on two parallel treads. One end of the track shall contain a Dead-end pulley (Model 1634) with a 1 - 1/4" diameter steel ball-bearing wheel, adjustable for cable tension. The other end shall be equipped with a Live-end pulley (Model 1603) with 2 each 1 - 1/4" diameter steel ball-bearing wheels. System shall be furnished with a Floor pulley (Model 1135) equipped with a tension spring to maintain tension on the operating cord (Model 1150).

Model 160 as manufactured by Automatic Devices Company of Allentown, PA.

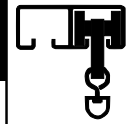

Model 160 Assembly
(Right Side Configuration)



Model RCS-2
Remote Control
Station

MOTO-TRAC® MODEL 160

MOTO-TRAC is a straight, motorized, aluminum track for light-to-medium weight draperies. The track can be one-way draw or bi-parting. Unlimited center overlap can be specified as an option. The curtain machine is attached to the track channel and may be located at either end of the track (must be specified when ordering) where it is concealed by the drapery fabric. Curtain machine characteristics are similar to those of Tom Thumb Model 872-MCS except that the limit switches are located at one end of the track. The curtain stops automatically at its fully opened and fully closed positions.

WHEN ORDERING PLEASE ADVISE:

1. If operation will be bi-part or one-way.
2. If system will be motorized or manual operation.
3. If the machine is located on the left or right side of the track.
(Perspective is inside looking out the window)

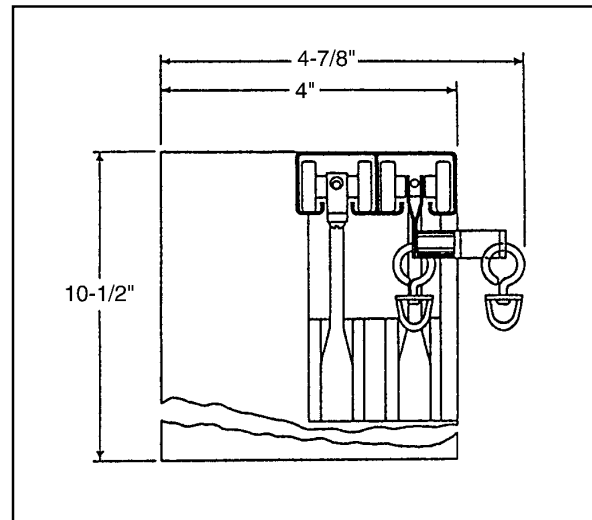

**Cross Section
of 160 Track**

Min. pocket width: 5-3/4 in.

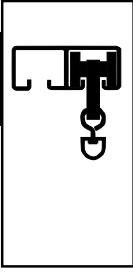

**No. 1600 Channel**

1' - 7 oz.

16 gauge extruded aluminum, anodized finish. Obtainable in unspliced lengths up to 20'.

Approximately: 2-1/8" wide x 7/8" high.

**No. 1131 Single Carrier**

2 - 1 oz.

Carrier spacing: 6". Block, providing "bumper-to-bumper" action, supported from 2 polyethylene wheels. Plated swivel for free, effortless and quiet curtain movement.

Carrier width: Approximately 1-3/16".

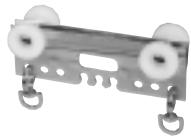
**No. 1602 Master Carrier**

1 - 2 oz.

Block constructed of plated steel supported from 4 polyethylene wheels. Provides unlimited center overlap with one curtain riding in front channel of track and one curtain riding in back channel of track.

Carrier width: Approximately 1".

**No. 1132 Master Carrier**

1 - 4 oz.

Similar to No. 1602 except equipped with 4" extension arm. Used on one-way draw tracks. Also used on pinch-pleat installations in which all carriers are placed in the front channel.

Carrier width: Approximately 1".

**No. 1602-R Master Carrier**

1 - 2 oz.

Block constructed nylon and steel supported from 4 polyethylene wheels. Placed in rear channel to turn off limit switch on drapery machine when draperies reach fully closed position.

Carrier width: Approximately 1".

**No. 1602-D Master Carrier**

1 - 7 oz.

Double block constructed of steel supported from 8 polyethylene wheels. Used on pinch-pleat installations in which all carriers are placed in the front channel.

Carrier width: Approximately 2-1/8".

**No. 1624 Splicing Clamp**

1 - 4 oz.

Steel clamp for joining sections assuring proper track alignment.

Approximately: 6" long.

**No. 1604 Adjustable Dead End Pulley**

1 - 1 lb. 1 oz.

Equipped with 1-1/4" diameter steel ball-bearing wheel adjustable for cord tension. Anchored to track end opposite curtain machine. Also functions as end stop.

Extends 2-1/2" beyond track end.

Pulley width: Approximately 2-1/4".

**No. 1135 Tension Floor Pulley**

1 - 3 oz.

Equipped with 1 nylon ball-bearing wheel. Tension spring provides cord tautness.

Approximately: 1" long x 3/4" wide x 7" high.

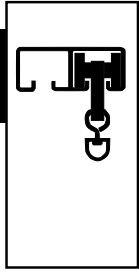

No. 1150 Cord

100' - 7 oz.
Synthetic center and stretch-resistant. For manually-operated tracks.
1/8" (No. 4)



No. C040 Cable

100' - 1 lb. 3 oz.
Wire center with extruded nylon cover.
1/8" (No. 4)



No. 1603 Live End Pulley

1 - 8 oz.
Used with hand-operated Model 160 track systems. Guides the operating cords down to floor pulley located below the live end pulley.
Approximately: 2" long x 2" high x 2" wide.



Curtain Machine

1 - 14 lbs.
1/30 HP gearmotor with limit switches activated by the drapery carriers. Can be placed at either end of the track (must be specified when ordering) and can be operated by remote control switches or by optional wireless remote control.
(See description of Tom Thumb® Model 872-MCS on page 103 for electrical characteristics.)
Approximately: 7" long x 4-1/8" wide x 10-1/4" high.



Model RCS-2 Remote Control Station

Brushed steel surface with 3-momentary push button operators.

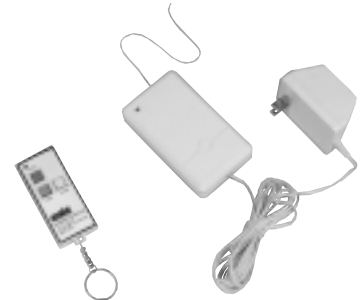

WRC-1 Wireless Remote Control

ADC's Wireless Remote Control System is ideal for operating one or more drapery machines from a hand-held transmitter. The system, which operates by radio remote control, allows total flexibility in room layout because furniture and/or drapery fabrics do not interfere with the signal. Receivers measure 4-3/8" long x 2-1/2" wide x 1" deep and require a 110 volt power source. Transmitters measure 3" long x 1-3/8" wide x 3/4" deep. Start, stop and reverse control is standard.

Low Voltage Control is required on machines using Model WRC-1 Wireless Remote Control.

When considering using a Model 160 for a project please note the following:

- Curtain width must not exceed 20'.
- Curtain weight must not exceed 80 pounds total.
- Curtain machine is hardwired and requires a 120 Vac, 60 hz power source.
- Remote controls (unless WRC-1 is used) are hardwired. Control circuit is a Class 2 type circuit and requires 4 conductors plus a ground.
- Curtain machine utilizes a 1/30 HP fixed speed AC gearmotor.
- Track is designed for direct mounting to an overhead structure.
- Carrier spacing is 6".
- Curtain hangs below the track.

Installation Instructions for Moto-trac Model 160 Curtain Track and Machine

General Information

The Model 160 curtain track and machine system is designed to be assembled on a workbench, or on the floor prior to mounting to an overhead structure.

The Model 160 track system is designed for direct ceiling mount only and should not be suspended from an overhead support with chain, cable, rope or any other such suspension media.

A qualified electrician will be needed to run a 120 VAC, 60HZ, 5 ampere power source to the machine in addition to the remote control wires. If the Model 160 you have purchased is equipped with low voltage control (standard configuration) four (4) control wires rated for 24 VDC, 1 ampere should be run from the machine's location to the remote control site. Check your local and the national electrical code for the correct size and type wire to be used for the remote control and power wiring.

The remote controls for the Model 160 system (Model RCS-1) are designed to attach to a standard single gang electrical box. Although only one remote is supplied with the machine, any number of RCS-1 remote control stations can be used with this model machine. A terminal strip is provided inside of the machine for all electrical connections.

Assembly

1. Place track on workbench, or floor with slots facing upward (track inverted).
2. Attach curtain machine to track using threaded bolts (2) provided with the curtain machine and the threaded holes (2) provided in the machines extended bracket. These bolts are designed to hold the machine and track together during the installation process only, and must be replaced with mounting bolts, or screws during the final mounting process .
3. Secure one end of the operating cable to one of the master carriers of the track by threading the cable through half of the carrier body, out the carrier window and between two (2) retaining fingers of the carrier body. The cable is

secured by forcing it between the retaining fingers of the carrier body and is further secured by attaching one of the cable clamps provided with the system which the cable is threaded through, the clamp placed against the carrier body, and its securing bolt tightened. Do not install the master carrier in the track at this time. Route the remaining cable through the front (room side) channel of the 1600 track, around the drive wheel of the machine, and through the rear (window side) channel of the 1600 track leaving one end of the cable free, and the other end attached to the master carrier.

4. Slide half of the 1131 single carriers into the front channel of the 1600 track followed by the master carrier that the operating cable is attached to. Make sure that this master carrier is installed in the front channel of the 1600 track along with the single carriers. When sliding in the single carriers, be sure to keep the operating cable between the body of the single carriers and the track surface as well as between the single carrier wheels.

5. Thread cable located in the rear channel of the 1600 track through the knock-off master carrier body, and slide the knock-off master into the rear channel of the 1600 track. Do not tighten the screws of the knock-off master at this time.

6. If the track system you are installing was ordered for a limited overlap follow Step A below.

If the track system you are installing was ordered for unlimited overlap follow Step B below.

A. Limited overlap

1) Thread free end of cable (cable in the rear channel) around the dead end pulley which should be placed at the open end of the 1600 channel (end opposite the machine).

2) Thread the cable run through the dead end pulley in the above step completely through the second master carrier's body and slide the master carrier into the front channel of the 1600 track.

3) With the cable laying on the bottom of the channel slide the remaining single carriers into the front channel between the second master carrier, installed in step 2, and the dead pulley. Be sure that the operating cable remains between the track's surface and the top of the carrier bodies, as well as between the single carriers wheels.

3) The free end of the cable from step 2 above is now threaded through the front half of the first master carrier's body and immediately out the

carrier's body window.

4) Align the dead end pulley mounting bracket with the 1600 channel making sure that the mounting extension of the bracket is between the track surface and the workbench, or floor.

5) Pull excess cable slack out of system at the second master carrier by pulling on the free end of cable coming out of the carrier body window. This process should pull the dead pulley into place against the track end. It is suggested that the cable be pulled with a pliers, or other such tool, to assure that sufficient tension is applied to the track system. When sufficient tension is applied, the cable should be secured at the master carrier by forcing it between two of the fingers of the master carrier and installing one of the cable clips provided with the system.

6) Slide both master carriers to the center of the track creating the predetermined overlap.

7) Pull the cable that is now going through the second master carrier's body through the carrier body window and up and into the master carrier fingers to secure the master carrier to the operating cable. You should use a needle nose pliers for this step.

8) Keeping the master carriers located at the center of the track, and with the overlap intact, slide the knock-off master carrier located in the rear channel of the track towards the machine until it engages the limit switch arm extending into the rear channel. Tighten the screws of this carrier securing it to the operating cable.

9) The track system is now fully assembled and adjusted and may be carefully inverted and mounted in place. During the mounting process be sure to verify that none of the mounting bolts or screws are installed at an angle, or partially installed, causing the screw or bolt head to protrude into the track channel and possibly binding the system. The tolerance between the carrier body, operating cable, and track is very small and any slight obstruction may cause the system to bind.

B. Unlimited overlap

1) Take the cable that was pulled through the knock-off master carrier during the main installation procedure and thread it completely through the second master carrier body.

- 2) Slide the second master carrier into the rear channel of the 1600 track followed by the remainder of the single carriers making sure that the operating cable remains between the single carrier bodies and the track surface as well as remaining between the carrier's wheels.
- 3) Align the dead end pulley with the open end of the track and route the operating line threaded through the knock-off master in the step 2, around the dead end pulley wheel and into the front channel of the 1600 track.
- 4) Thread the free end of the cable from step 3 above through half of the first master carrier body and immediately out the carrier's window.
- 5) Using a pliers, or other similar tool, pull the slack out of the operating cable by pulling on the free end of the cable protruding from the first master carrier's window. This process should pull the dead end pulley toward the track and align it with the track. Be sure to verify that the dead end pulley's extended mounting bracket is located between the track surface and the workbench, or floor. Be sure to apply sufficient tension to the system to eliminate any possibility of cable slippage on the drive wheel of the machine.
- 6) Secure the cable to the master carrier body by forcing it through the body's finger and installing one of the cable clips provided with the system.
- 7) Slide the two master carriers of the track system towards the center of the track and bypass the carriers an amount equal to the amount of overlap required.
- 8) Pull the cable that is going through the body of the second master carrier through the body's window and up and into the fingers of the master carrier body. Secure the cable loop to the carrier by forcing the cable through the fingers of the carrier body.
- 9) Slide the knock-off master carrier toward the machine until it engages the limit switch actuating arm that extends into the rear channel and secure the carrier to the cable by tightening the screws located on the carrier's body.
- 10) The track system is now fully assembled and adjusted and may be carefully inverted and mounted in place. During the mounting process be sure to verify that none of the mounting bolts or screws are installed at an angle, or partially installed, causing the screw or bolt head to protrude into the track channel and possibly binding the system. The tolerance

between the carrier body, operating cable, and track is very small and any slight obstruction may cause the system to bind.

Mounting

1. Mount the track system to the ceiling, or overhead structure using appropriate mounting hardware for the type of overhead structure that exists. After the track has been adequately supported along its length, remove the two (2) mounting bolts from the machine that were used during the assembly process and replace them with mounting screws, or bolts that will attach to the overhead structure.
2. Have an electrician connect the power source and remote control wires to the machine according to the wiring diagrams included with the machine.
3. It is recommended that the track system be tested prior to installing the curtain on the track to assure correct operation. To test the system have one (1) person operate the remote control unit and one (1) person observe the operation of the track. The person operating the remote control should be ready to engage the STOP button at all times in the event that a problem arises. The system should operate freely and should shut off automatically in each direction. The knock-off master carrier is responsible for shutting the machine off in one direction and the last single carrier in the front channel is responsible for shutting the machine off in the other direction.
4. With the track tested and approved the curtain may now be installed to the track system.

Troubleshooting:

<u>Symptom</u>	<u>Remedy</u>
1. Machine will not start from remote.	Check incoming power source for correct voltage.

- | | |
|--|--|
| | <p>Check remote control wire connections. (power removed).
Check main fuse for fault.
Check limit switches for operation and alignment.
Check stop button of remote control (power removed). It must be normally closed and momentary operation.</p> |
| 2. Machine stalls out along its travel. | <p>Curtain weight or track resistance (friction) is too high. Curtain must be lightened or track must be changed to lower resistance.</p> |
| 3. Machine will not achieve full speed. | <p>Machine is operating near its maximum allowable load rating. Check weight of curtain and resistance of track system.</p> |
| 4. Machine will not shut off at limits. | <p>Check operation of the limit switches with a VOM (power removed) and verify their operation.
Check wiring and connections for the limit switch wires (power removed).
Check alignment of carriers and limit switch activating arm.</p> |
| 5. Operating cable slips during operation. | <p>Remove slack from system (see section covering this procedure in manual).
Curtain is too heavy for machine and must be lightened.</p> |
| 6. Operating cable continually stretches. Verify | <p>that wire center and not synthetic center cable is being used in the track system.
If wire center cable is being used the curtain weight exceeds the design characteristics of the curtain track. Change the curtain track and machine.</p> |
| 7. Machine blows fuses. | <p>Short circuit exists in the machine.
Remove machine from service and return to factory for inspection and</p> |

repair.

Wireless systems:

1. Machine does not operate from transmitter. Check battery strength of transmitter.
Check code in transmitter and receiver and verify they are the same.
Transmitter is out of range of receiver.
Move transmitter closer to receiver.
Antenna of receiver is obstructed.
Antenna must be extended in open air and preferably in line of sight of transmitter.
Check voltage to receiver and verify that power source is active.

Specifications for 160 Moto-Trac

General Information

Name of appliance and category:	Drapery Motor/Track System
Type:	Moto-Trac Model 160
Manufacturer:	Automatic Devices Company 2121 South 12th Street

Country of origin:

Allentown, PA 18103
United States of America

Technical Information

Voltage:	120 VAC (+/- 10%)
Current:	0.6 Amperes FLC
Power Coefficient:	N.A.
Rated operation:	Intermittent duty operation only
Mass (weight):	6.36 kg (14 lbs)
Frequency:	60 Hertz
Power:	50 Watt
Dimensions:	10 cmL x 10 cmW x 27 cmH (4"L x 4"W x 10.5"H)
UL File Number (standard unit):	E60360 (Listed 717E)
ETL File Number (standard unit):	N.A.
Field Connection Method:	Screw type barrier strip
Fuse Type:	MDX (0.6A, 250 VAC)
Relay Board:	Model B070
Relay type:	Potter Brumfield KH series 4PDT, 24 VDC coil.
Limit Switch:	Omron (15 amp at 125, or 250 VAC)
Machine Cover:	24 gauge painted sheet steel.

REV

DATE:

SECTION VIEW

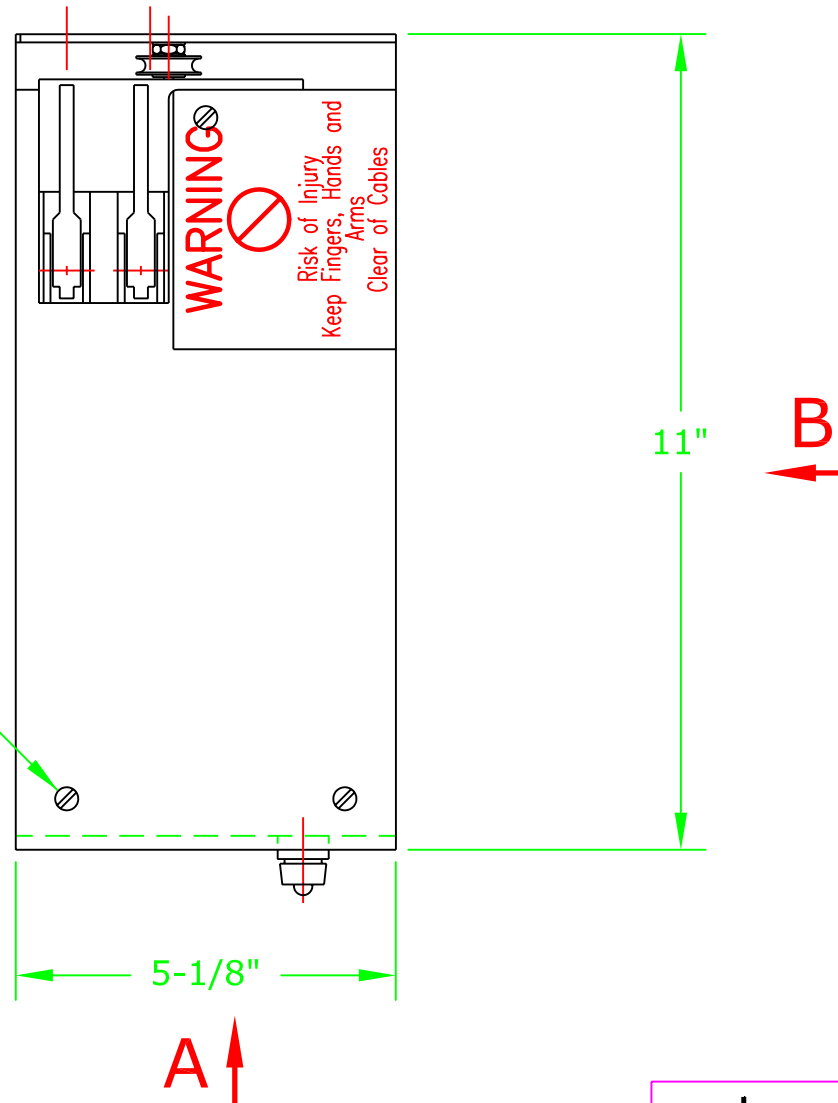

REMOVE SCREWS (7 TOTAL)
TO REMOVE COVER

NOTES:

- 1 FOR ADDITIONAL VIEWS, SEE SHEETS 2 AND 3.
- 2 MACHINE AND TRACK MUST BE MOUNTED DIRECTLY TO OVERHEAD STRUCTURE.
- 3 USE MODEL RCS-1 REMOTE CONTROL STATIONS.
- 4 POWER SOURCE AND REMOTE CONTROLS ARE HARDWIRED TO THE MACHINE.



AUTOMATIC DEVICES COMPANY
2121 S. 12TH ST. ALLENTOWN, PA 18103

THIS DRAWING HAS BEEN PREPARED AS A SERVICE TO OUR CUSTOMER AND IS INTENDED ONLY TO BE SUGGESTIVE IN NATURE AND IS NOT TO BE USED AS AN ACTUAL INSTALLATION DRAWING. PREVAILING JOB CONDITIONS AND ACCEPTED PRACTICES MUST BE TAKEN INTO ACCOUNT WHEN THE EQUIPMENT IS INSTALLED.

SIZE	DATE	SERIES
A	10/23/02	160 MOTO-TRAC
DRAWN BY	APPROVED BY	DESCRIPTION
JEK		LEFT HAND CONFIGURATION
SCALE 3/8=1	SHEET 1 OF 3	DWG NO. M-160L-1-02

REV | DATE:

SECTION VIEW

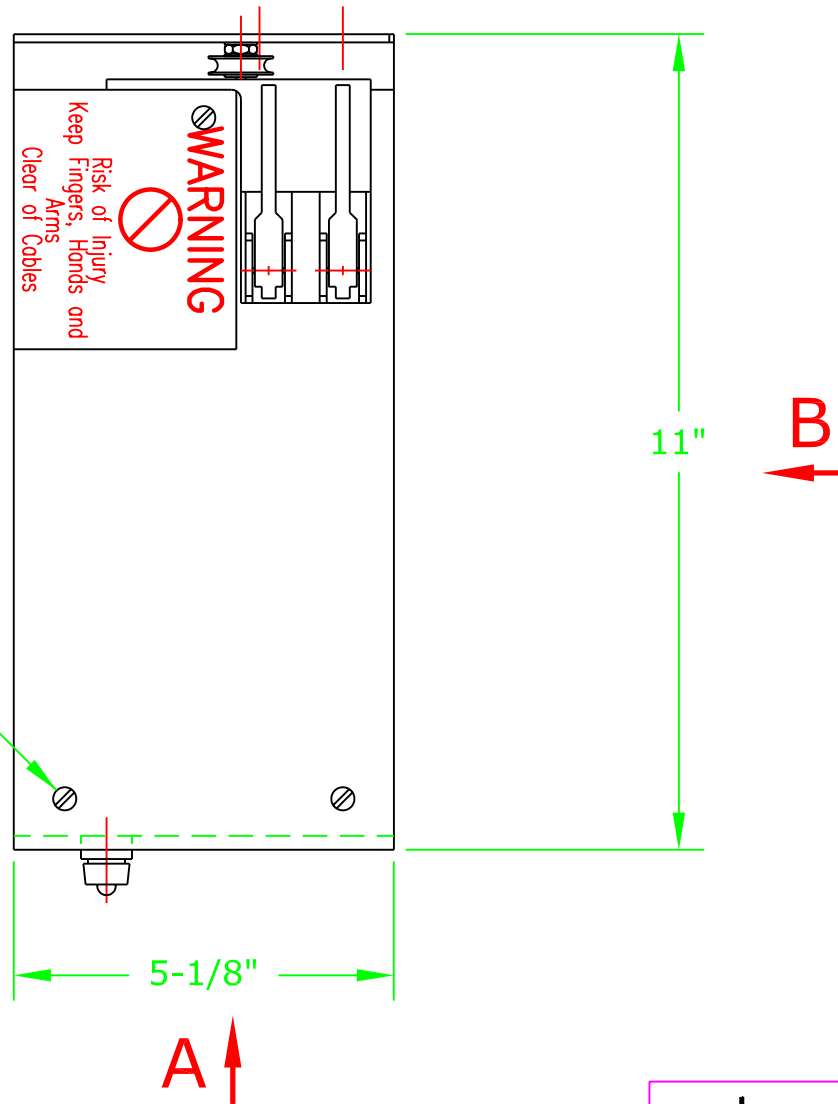

NOTES:

- 1 FOR ADDITIONAL VIEWS, SEE SHEETS 2 AND 3.
- 2 MACHINE AND TRACK MUST BE MOUNTED DIRECTLY TO OVERHEAD STRUCTURE.
- 3 USE MODEL RCS-1 REMOTE CONTROL STATIONS.
- 4 POWER SOURCE AND REMOTE CONTROLS ARE HARDWIRED TO THE MACHINE.

ade		AUTOMATIC DEVICES COMPANY 2121 S. 12TH ST. ALLENTOWN, PA 18103	
THIS DRAWING HAS BEEN PREPARED AS A SERVICE TO OUR CUSTOMER AND IS INTENDED ONLY TO BE SUGGESTIVE IN NATURE AND IS NOT TO BE USED AS AN ACTUAL INSTALLATION DRAWING. PREVAILING JOB CONDITIONS AND ACCEPTED PRACTICES MUST BE TAKEN INTO ACCOUNT WHEN THE EQUIPMENT IS INSTALLED.			
SIZE	DATE	SERIES	
A	10/22/02	160 MOTO-TRAC	
DRAWN BY	APPROVED BY	DESCRIPTION	
JEK		RIGHT HAND CONFIGURATION	
SCALE	SHEET	DWG NO.	
3/8=1	1 OF 3	M-160R-1-02	

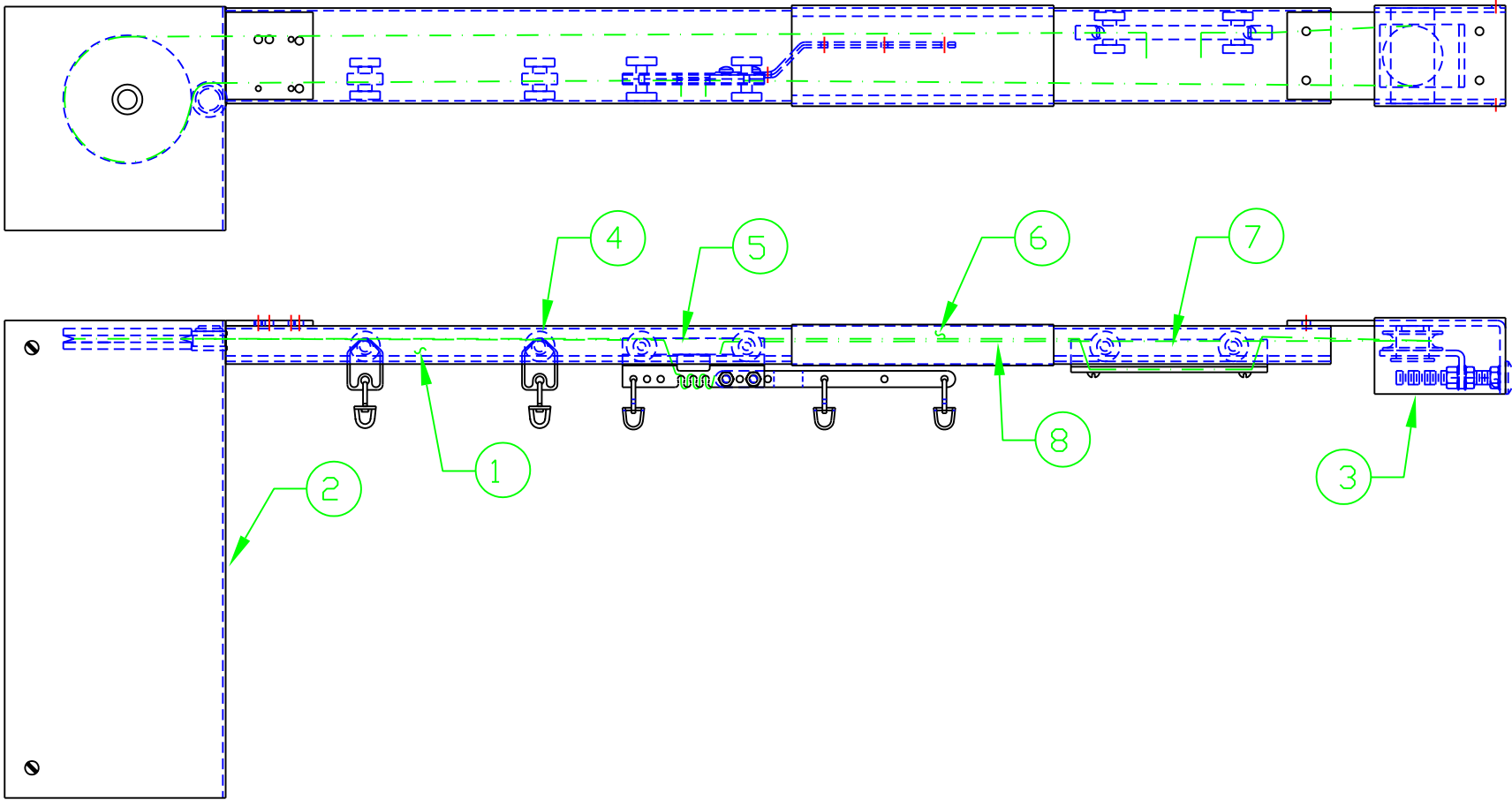

- ① 1600 TRACK
- ② CURTAIN MACHINE
- ③ 1634 ADJUSTABLE DEAD END PULLEY
- ④ 1131 SINGLE CARRIER
- ⑤ 1602-A MASTER CARRIER
- ⑥ 1624 SPLICING PLATE (IF NEEDED)
- ⑦ 1602-R MASTER CARRIER
- ⑧ C-40 CABLE

AUTOMATIC DEVICES COMPANY
2121 S. 12TH ST. ALLENTOWN, PA 18103

THIS DRAWING HAS BEEN PREPARED AS A SERVICE TO OUR CUSTOMER AND IS INTENDED ONLY TO BE SUGGESTIVE IN NATURE AND IS NOT TO BE USED AS AN ACTUAL INSTALLATION DRAWING. PREVAILING JOB CONDITIONS AND ACCEPTED PRACTICES MUST BE TAKEN INTO ACCOUNT WHEN THE EQUIPMENT IS INSTALLED.

SIZE	DATE	INSTALLATION INSTRUCTIONS	REV
A	08/25/98		
DRAWN BY		DESCRIPTION	
GAR		160 TRACK ASSEMBLY - ONE-WAY DRAW	
SCALE NTS		SHEET 1 OF 2	DWG NO. II-1600WD-98

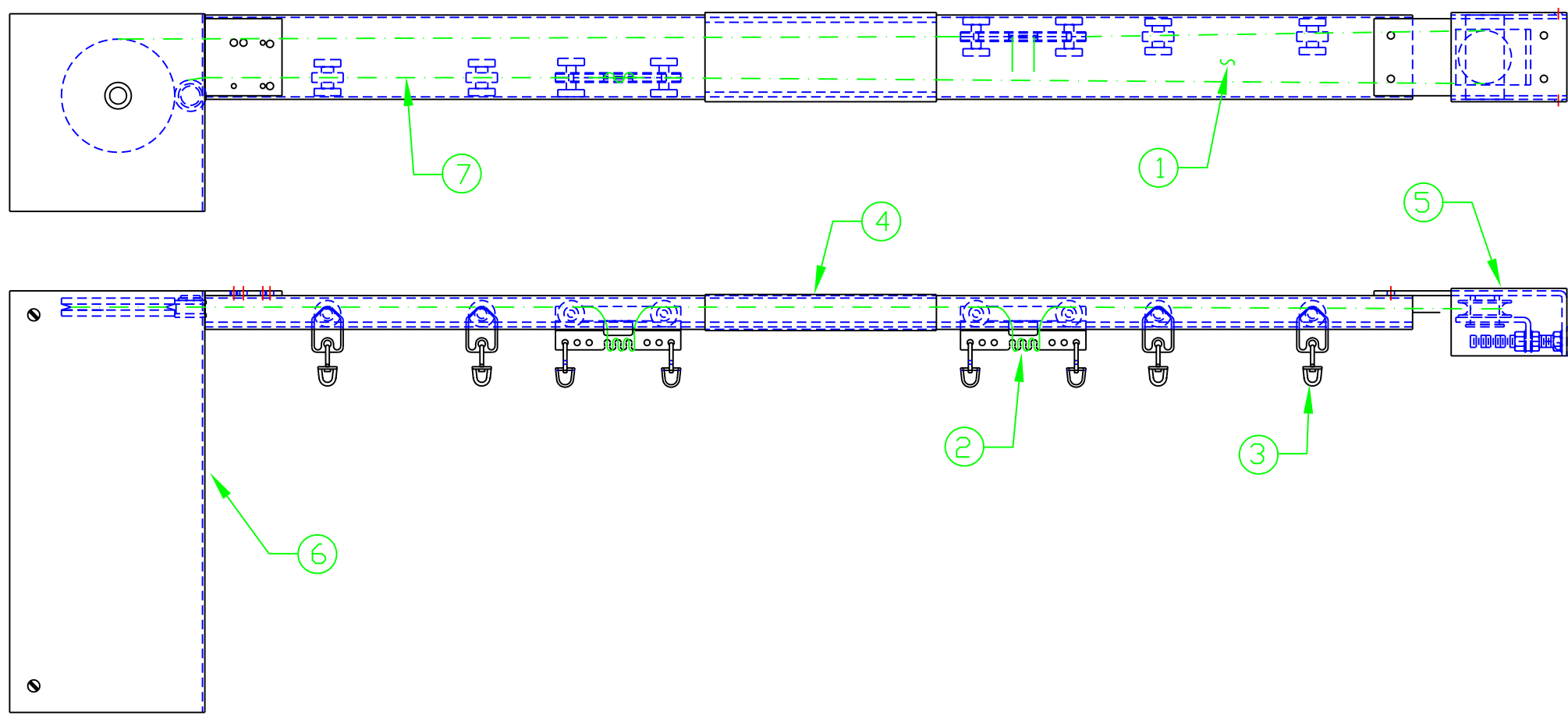

- ① 1600 TRACK
- ② 1602 MASTER CARRIER
- ③ 1131 SINGLE CARRIER
- ④ 1624 SPLICE CLAMP (IF NEEDED)
- ⑤ 1634 ADJUSTABLE DEAD END PULLEY
- ⑥ MACHINE OPERATOR
- ⑦ C-40 CABLE

AUTOMATIC DEVICES COMPANY 2121 S. 12TH ST. ALLENTOWN, PA 18103		
THIS DRAWING HAS BEEN PREPARED AS A SERVICE TO OUR CUSTOMER AND IS INTENDED ONLY TO BE SUGGESTIVE IN NATURE AND IS NOT TO BE USED AS AN ACTUAL INSTALLATION DRAWING. PREVAILING JOB CONDITIONS AND ACCEPTED PRACTICES MUST BE TAKEN INTO ACCOUNT WHEN THE EQUIPMENT IS INSTALLED.		
SIZE	DATE	INSTALLATION INSTRUCTION
A	08/26/98	
DRAWN BY	APPROVED BY	DESCRIPTION 160 TRACK ASSEMBLY -BI-PART STRAIGHT
GAR		
SCALE NTS	SHEET 1 OF 1	DWG NO. II-160DL-98

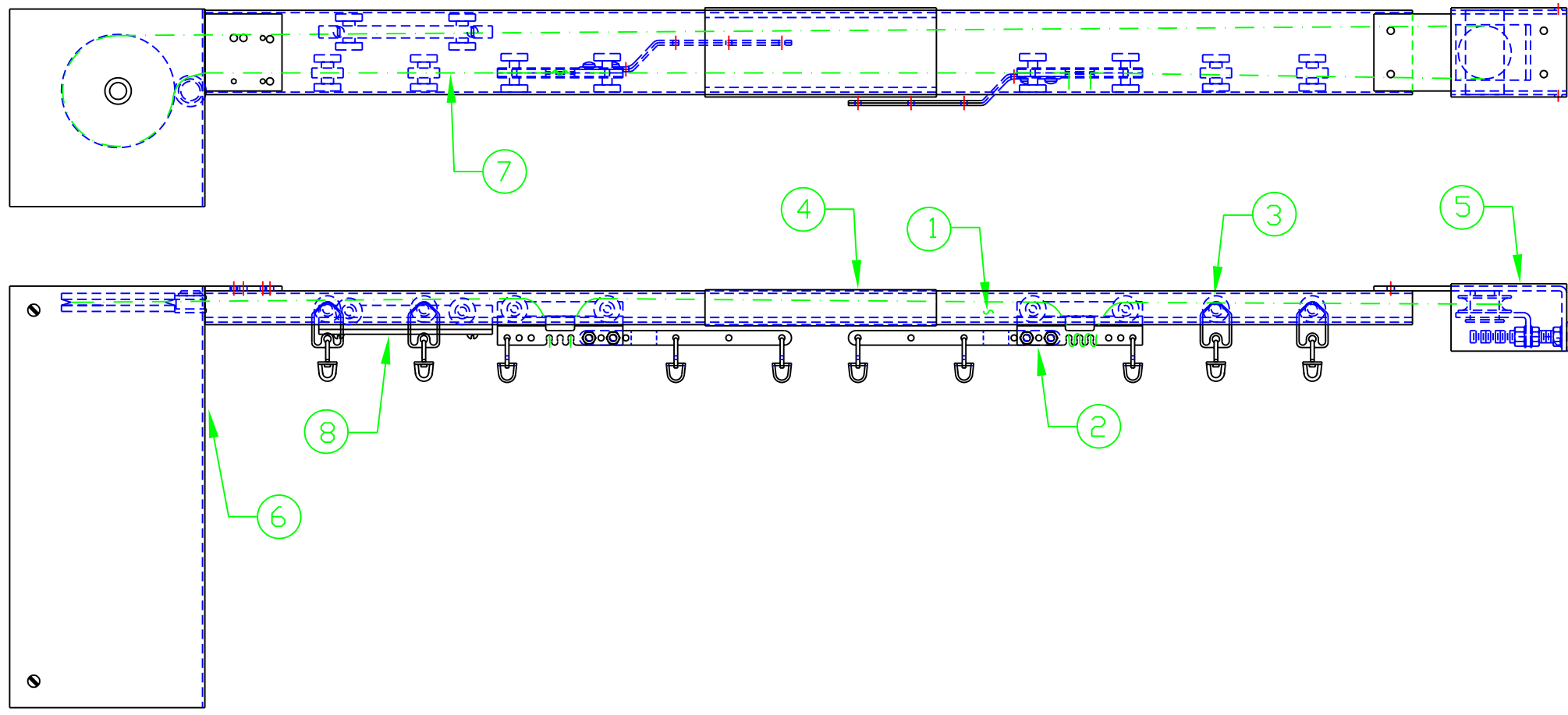

- ① 1600 TRACK
- ② 1602-A MASTER CARRIER
- ③ 1131 SINGLE CARRIER
- ④ 1624 SPLICE CLAMP (IF NEEDED)
- ⑤ 1634 ADJUSTABLE DEAD END PULLEY
- ⑥ MACHINE OPERATOR
- ⑦ C-40 CABLE
- ⑧ 1602-R MASTER CARRIER

AUTOMATIC DEVICES COMPANY 2121 S. 12TH ST. ALLENTOWN, PA 18103			
THIS DRAWING HAS BEEN PREPARED AS A SERVICE TO OUR CUSTOMER AND IS INTENDED ONLY TO BE SUGGESTIVE IN NATURE AND IS NOT TO BE USED AS AN ACTUAL INSTALLATION DRAWING. PREVAILING JOB CONDITIONS AND ACCEPTED PRACTICES MUST BE TAKEN INTO ACCOUNT WHEN THE EQUIPMENT IS INSTALLED.			
SIZE	DATE	INSTALLATION	REV
A	08/26/98	INSTRUCTIONS	
DRAWN BY	APPROVED BY	DESCRIPTION	
GAR		160 TRACK ASSEMBLY - OVERLAP W/ARMS	
SCALE	NTS	SHEET 1 OF 1	DWG NO. II-160UNDL-98

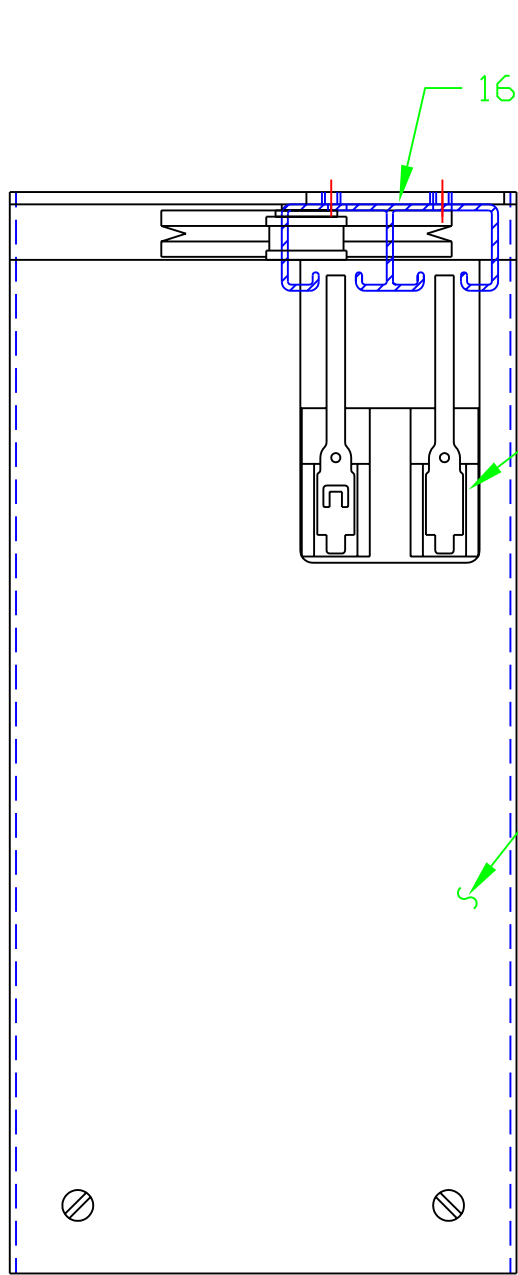

END VIEW OF CURTAIN MACHINE

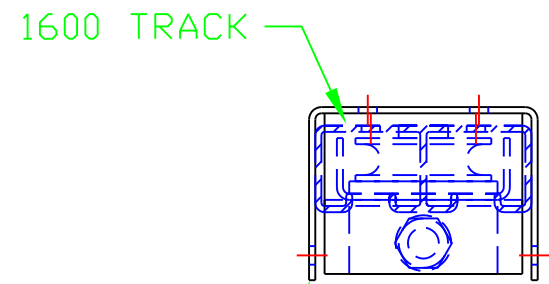

END VIEW OF ADJUSTABLE DEAD END PULLEY

LIMIT SWITCHES

1634 ADJUSTABLE DEAD END PULLEY

1602-A OR 1602 MASTER CARRIER

C-40 CORD

1600 TRACK

CURTAIN MACHINE

1602-R MASTER CARRIER

SECTION VIEW OF MASTER CARRIER

AUTOMATIC DEVICES COMPANY 2121 S. 12TH ST. ALLENTOWN, PA 18103			
THIS DRAWING HAS BEEN PREPARED AS A SERVICE TO OUR CUSTOMER AND IS INTENDED ONLY TO BE SUGGESTIVE IN NATURE AND IS NOT TO BE USED AS AN ACTUAL INSTALLATION DRAWING. PREVAILING JOB CONDITIONS AND ACCEPTED PRACTICES MUST BE TAKEN INTO ACCOUNT WHEN THE EQUIPMENT IS INSTALLED.			
SIZE	DATE	INSTALLATION	REV
A	09/15/98	INSTRUCTIONS	
DRAWN BY	APPROVED BY	DESCRIPTION	
GAR		END VIEW OF CURTAIN MACHINE & 1634	
SCALE	NTS	SHEET 2 OF 2	DWG NO.